

( )가

[ ] [ ] < 1>

가

( )

< 1>

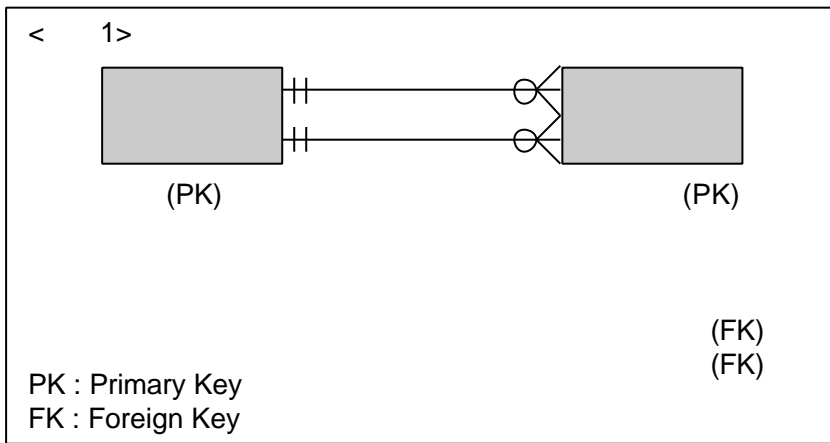

가

가

가

< 2.가>

< 2.가>

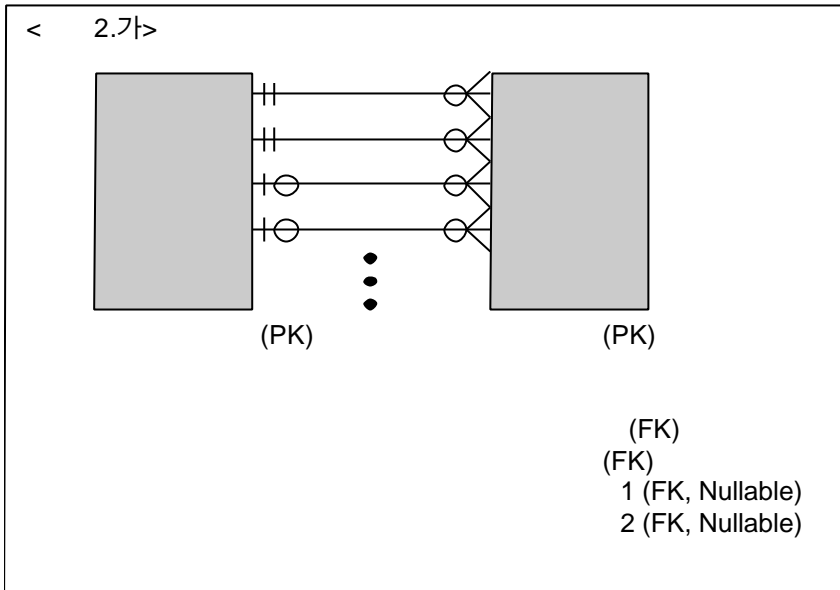

가 가

< 2. > 가 . < 2. >  
[ ] [ ] [ ]

< 2. > . < 2. >  
가

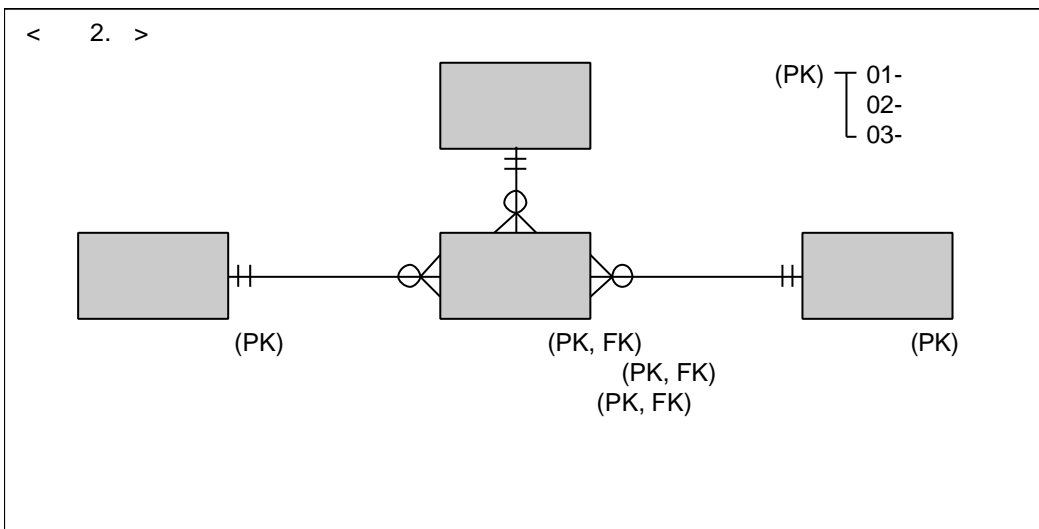

5 가 . 가  
 가 . ,  
 ; 가 .  
 .  
 < 3.가> . , < 3.가>  
 가 .

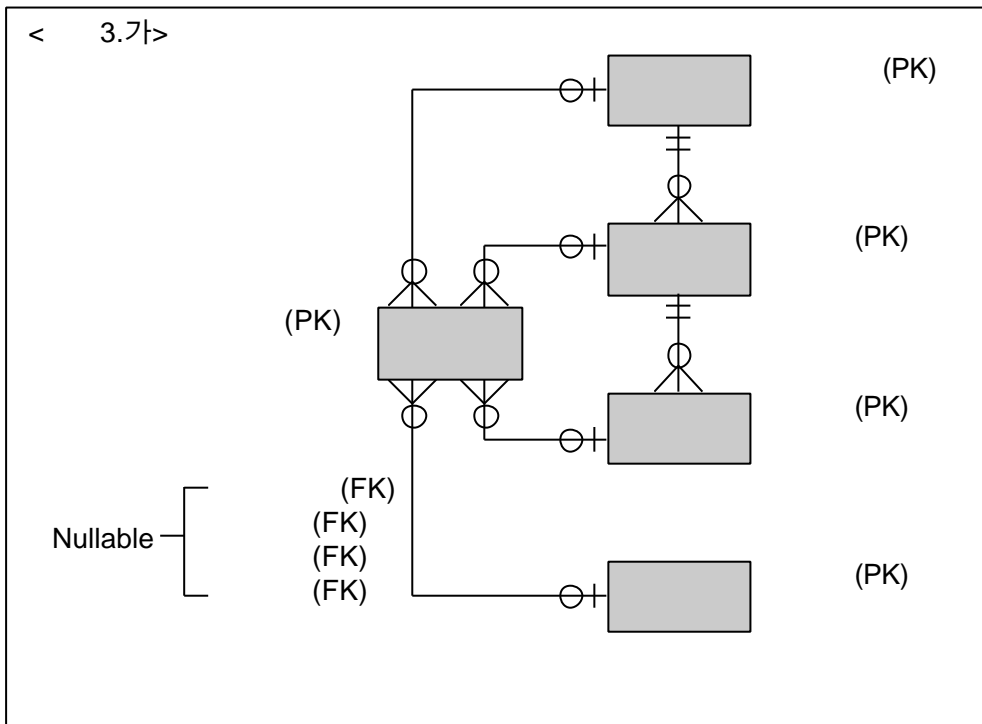

가 . < 3.가>  
 [ ] , , , . , [ ]  
 ,  
 . < 3.가> ,  
 , < 3.가> [ ]  
 가  
 , < 3.가> 가 .  
 , [ ]  
 , 가  
 가 . ,

< 3. >

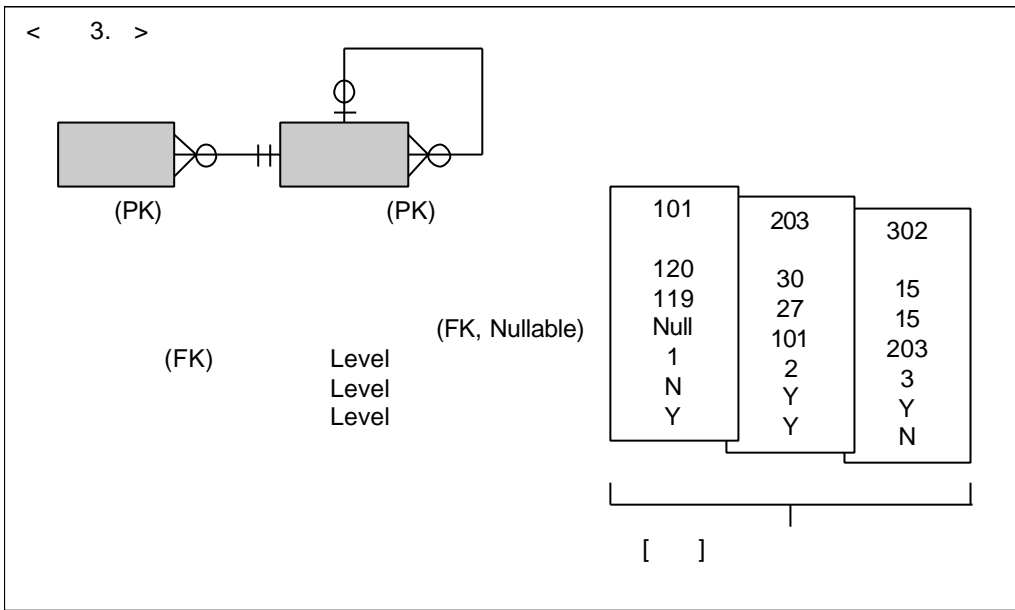

, , , [ ] , [ ]

[ ] Level, Level , Level  
Level

가

< 3. > , [ ]

가 [ ]

, < 3. >

가 [ ] . [ ]

, [ ]

, [ ]

, [ ]

가

( )

< 4.가> .

[ ]

가

(< 4.가>

) 가

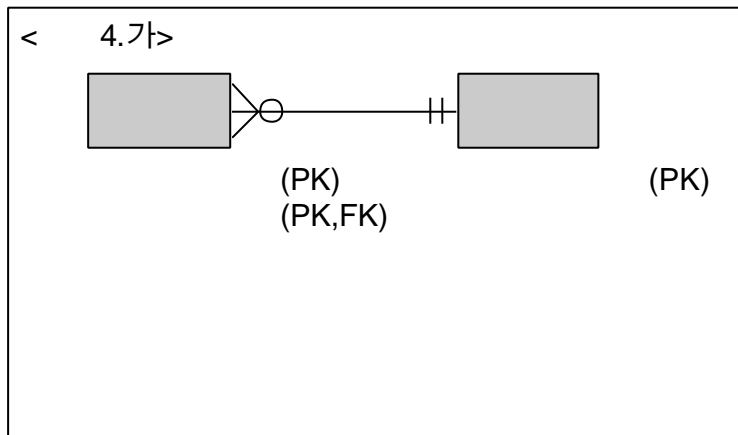

가

가

가

가

, < 4. >

가 .

[            ]  
(            )가

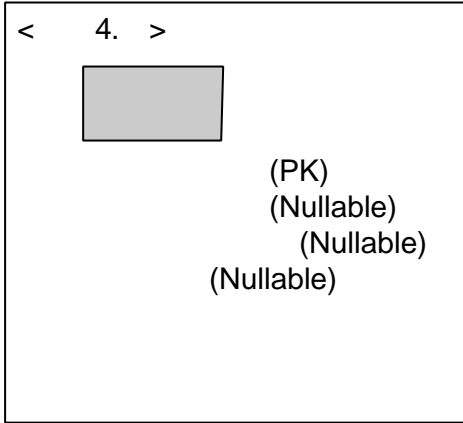

[            ]  
가

Nullable

가 가

, < 4.가 >

< 4.가 >

< 4. >

< 4. >

Nullable

< 4. >

< 4. >

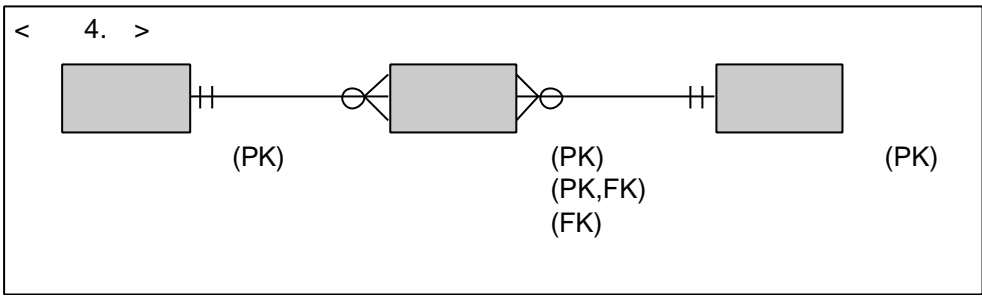

5%

가

6 가

< 5.가>

< 5.가>

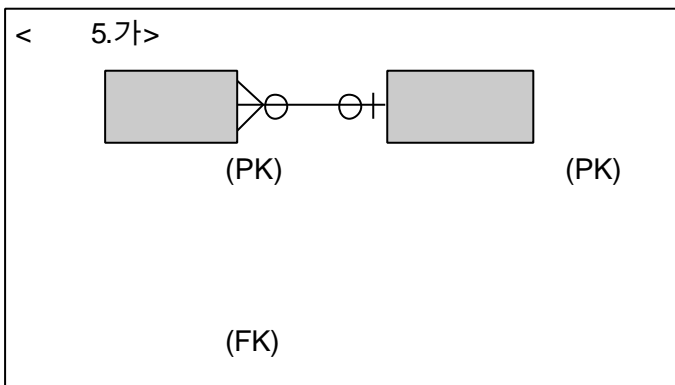

가

가

가

가  
가

< 5. >

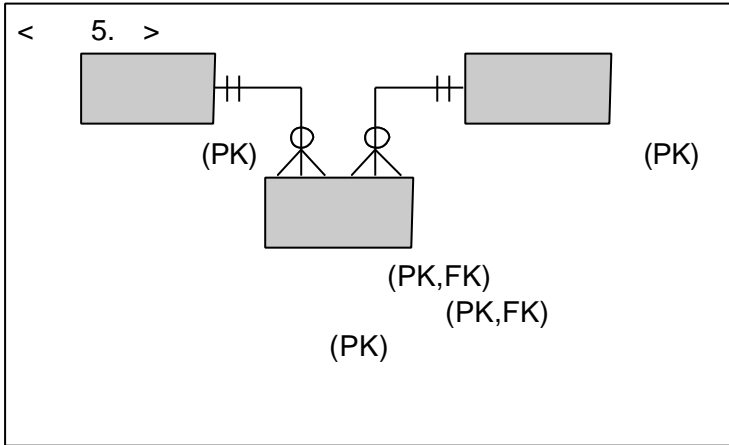

, < 5. >

가

, < 5. >



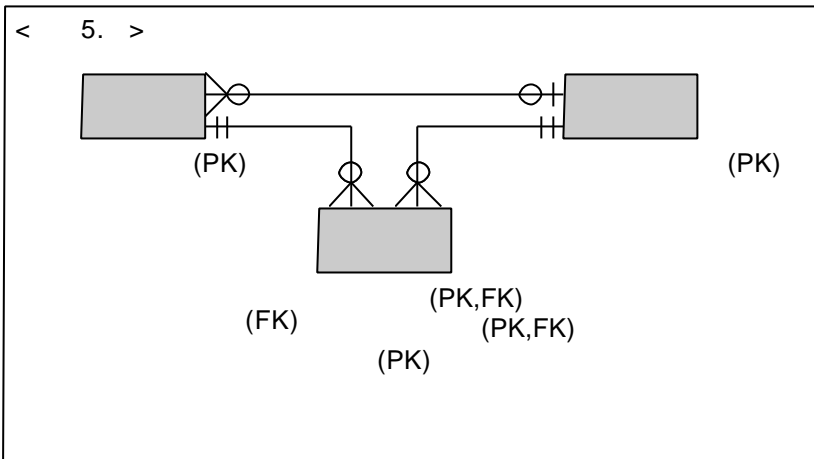

가

< 6.가> [ ], [ ], [ ] , [ ]  
 (Foreign Key)가

< 6.가>

< 6. > . [ ] ,

< 6. > 가 (Virtual Relationship)

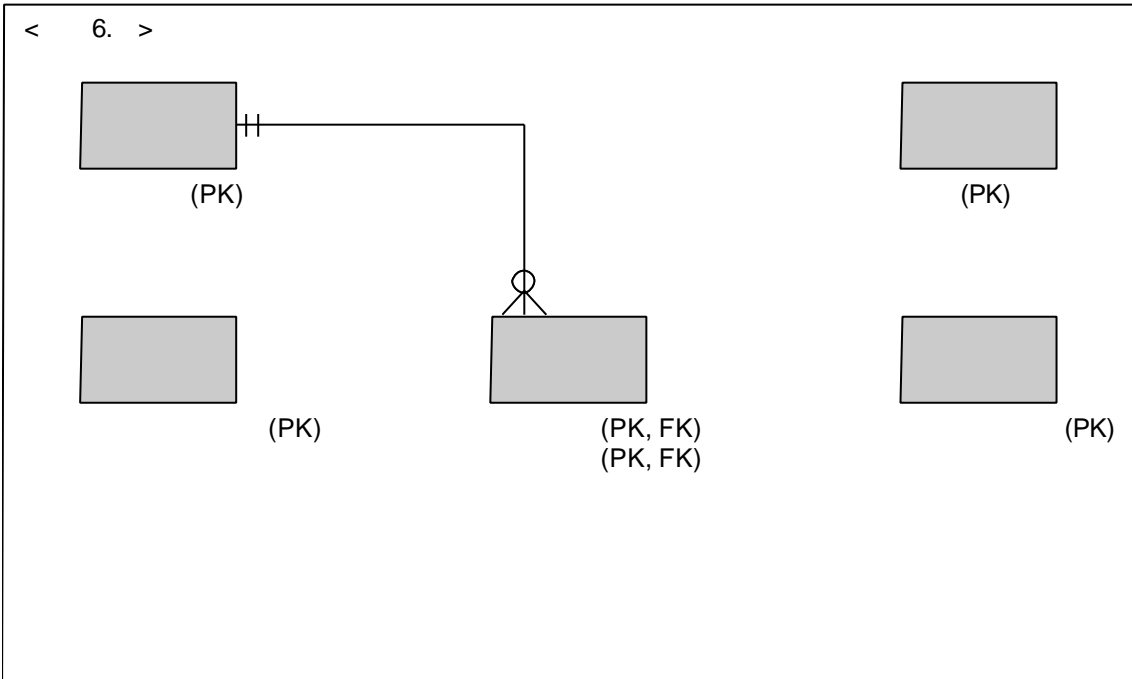
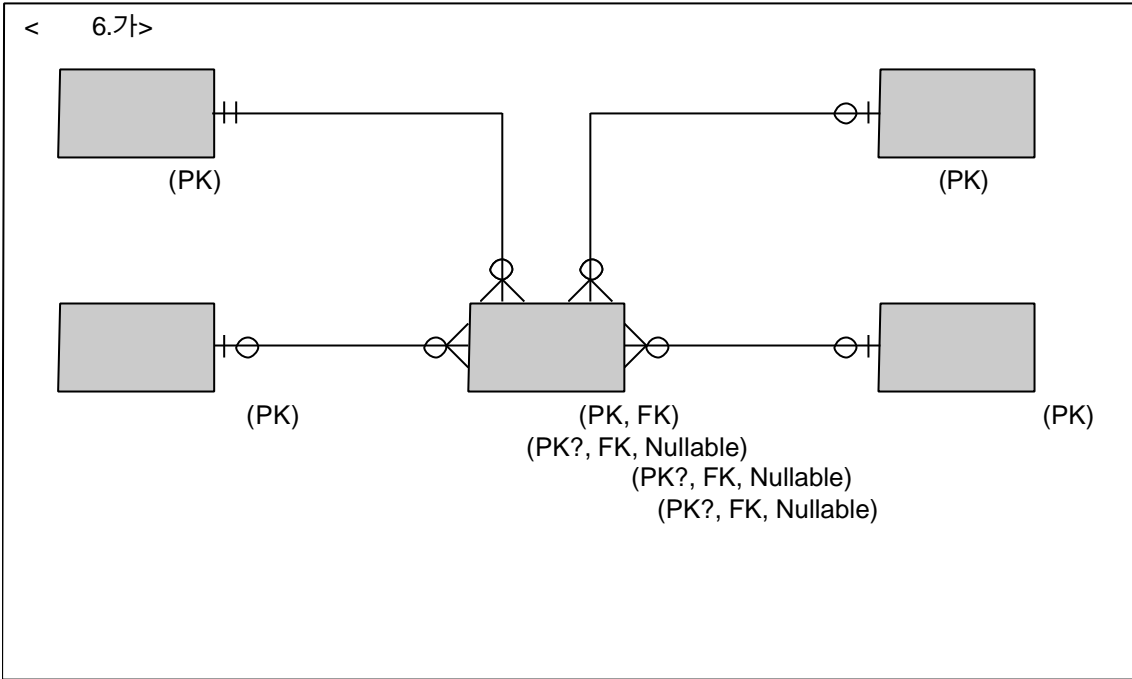

M : N

.

.

.

< 7.가 >

M:N , M:N , M:N  
가 , M:N

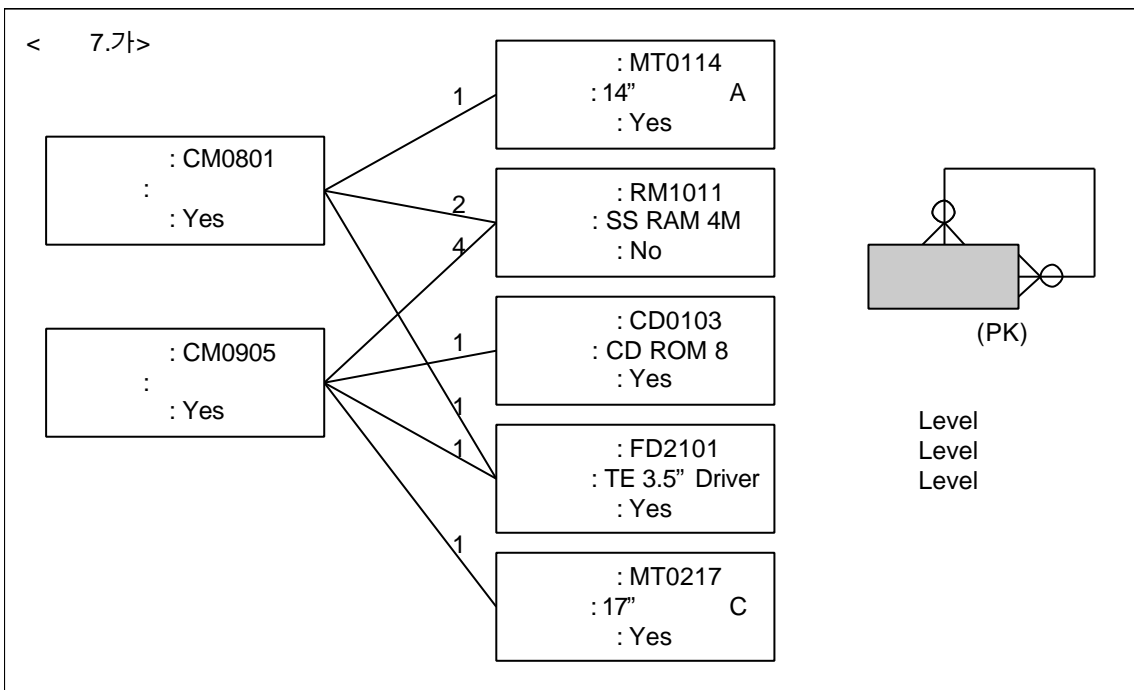

M:N < 7. > 가  
< 7. > 가

- 1)
- 2) M:N 가
- 3)

< 7. >  
[       ]

. < 7. >       가  
.

